

FL SERIES













INTERCHANGE > ISO 16028 - NFPA T3.20.15 - HTMA (size 3/8")



Stucchi®



TECHNICAL FEATURES AND OPTIONS

 Interchange ISO 16028 NFPA T3.20.15 HTMA (size 3/8")	 Sealing description FKM (VITON®)	 Connection system Push
 Available sizes from 1/8" to 2"	 Material Stainless steel (AISI 316L)	 Available threads BSP - NPT
 Operating pressure Up to 350 bar	 Locking mechanism Locking ball + Safety Lock	 Flow rate Up to 1000 L/Min
 Temperature (°C) -15° / +180°	 Valving style Flat face	 Connection under pressure Connection: not allowed Disconnection: not allowed

BENEFITS

- Flat face is easy to clean, reducing the inclusion of contamination inside the hydraulic circuit.
- Minimal fluid spillage during disconnection, reducing fluid spillage to the environment.
- Minimal air inclusion during connection.
- Optimal resistance to the corrosion for long life of couplings.
- Compact slim design.
- Safe and simple to use.

HOW TO USE

- Before to connect, clean the mating surface of the couplings to avoid dirt inclusion in the circuit.
- To connect push the male half towards the female half or vice versa.
- After connection turn the external sleeve to engage safety lock function, to prevent accidental disconnection.
- To disconnect turn the external sleeve until the sleeve lock notch match the safety lock ball and push back the sleeve.

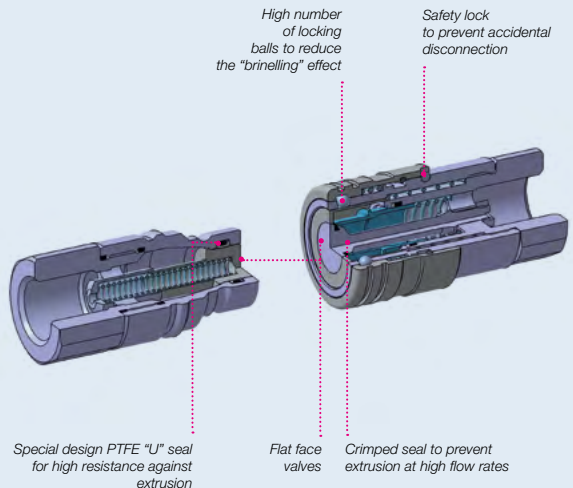
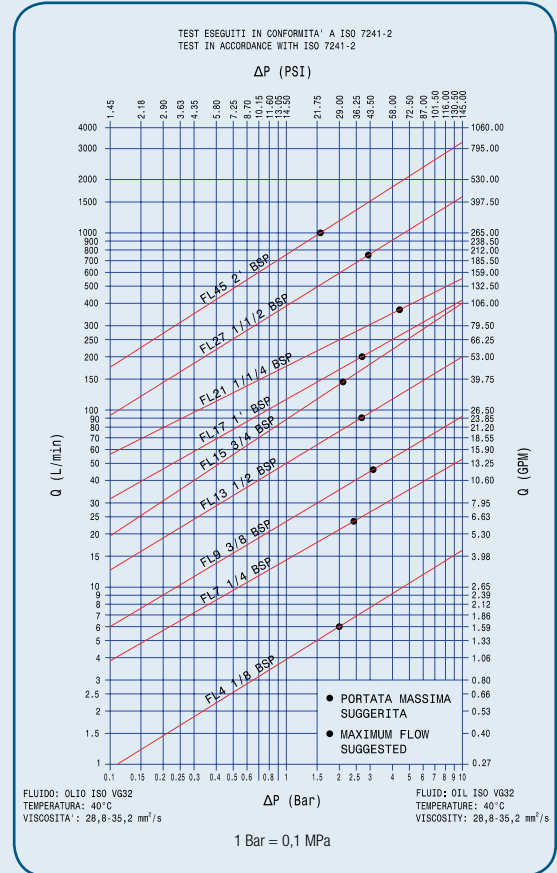

MAIN APPLICATIONS



ISO 16028

PERFORMANCES

Size		Series/Size	Max. flow suggested		Connect force		Disconnect force		Spillage*
Inch	mm (ISO)		l/min	GPM	N	lbf	N	lbf	ml
1/8		FL4	6	1,59	140	31,50	30	6,75	0,01
1/4	6,3	FL7	24	6,36	160	36,00	45	10,13	0,01
3/8	10,0	FL9	46	12,19	160	36,00	45	10,13	0,01
1/2	12,5	FL13	90	23,85	200	45,00	60	13,50	0,02
5/8	16,0	FL15	148	39,22	200	45,00	60	13,50	0,03
3/4	19,0	FL17	200	53,00	200	45,00	60	13,50	0,03
1	25,0	FL21	378	100,17	280	63,00	90	20,25	0,04
1-1/2		FL27	750	198,75	580	130,50	160	36,00	0,05
2		FL45	1000	265,00	490	110,25	70	15,75	0,10

Size	Series/Size	Max. operating pressure						Burst pressure					
		Coupled		Male		Female		Coupled		Male		Female	
Inch		MPa	psi	MPa	psi	MPa	psi	MPa	psi	MPa	psi	MPa	psi
1/8	FL4	35	5075	35	5075	33	4785	140	20300	140	20300	120	17400
1/4	FL7	35	5075	35	5075	12	1740	140	20300	120	17400	48	6960
3/8	FL9	35	5075	35	5075	15	2175	140	20300	120	17400	60	8700
1/2	FL13	35	5075	35	5075	15	2175	120	17400	110	15950	60	8700
5/8	FL15	35	5075	30	4350	12	1740	120	17400	100	14500	48	6960
3/4	FL17	33	4785	28	4060	12	1740	100	14500	80	11600	48	6960
1	FL21	28	4060	28	4060	12	1740	90	13050	80	11600	48	6960
1-1/2	FL27	23	3335	23	3335	8	1160	80	11600	70	10150	32	4640
2	FL45	15	2175	15	2175	7	1015	60	8700	60	8700	28	4060

*Spillage is an indicative value of the fluid loss during disconnection (according to ISO 7241-2 test method)

Different configuration possible:

Standard seal in VITON® (different seal available upon request)
Thread SAE available upon request

Material:

-Construction: Stainless steel AISI 316L
-Springs: AISI 302
-Locking ball: AISI 316

Temperature range:

Seals in VITON® : from -15°C to +180°C (from +5 °F to +356 °F).
NBR (Nitrile) : from -20 °C to +100 °C (from -4 °F to +212 °F)
EPDM (Ethylene Propylene) seals: from -40 °C to +150 °C (from -40 °F to +302 °F).
KALREZ® seals: from -25 °C to +300 °C (from -13 °F to +572 °F).

The couplings with KALREZ® seals for high temperature use can be used at max. operating pressure of 5 Mpa (725 psi).

Please read carefully "instruction and warning" for proper selection of the products.

Tests performed:

The couplings have been tested at max. operating pressure for 100.000 impulses according to ISO 7241-2 test method.



WARNING

A defect, a wrong choice or an improper use of products, can cause injury to persons, animals and objects.

Never connect or disconnect with dynamic pressure (e.g. pump on).
Do not use the female coupling disconnected with high impulse pressure.

Do not couple-uncouple with flow and/or pressure in the circuit.

Do not couple-uncouple when the temperature inside of the circuit is higher than 80 °C (176 °F).

Check the maximum allowable working pressure of the port in use.

Make sure that the medium used is compatible with seal and material as indicated for each series.

In case of doubt please contact Stucchi Technical Support.

The interchangeability is mentioned under the assumption that the manufacturer of the considered products has not changed any dimension.

It is MANDATORY to read and closely follow the instructions. Last updated version always apply at time of installation, see latest written Instructions on Stucchi website (www.stucchi.it) before selecting or using Stucchi products.

OVERALL DIMENSIONS

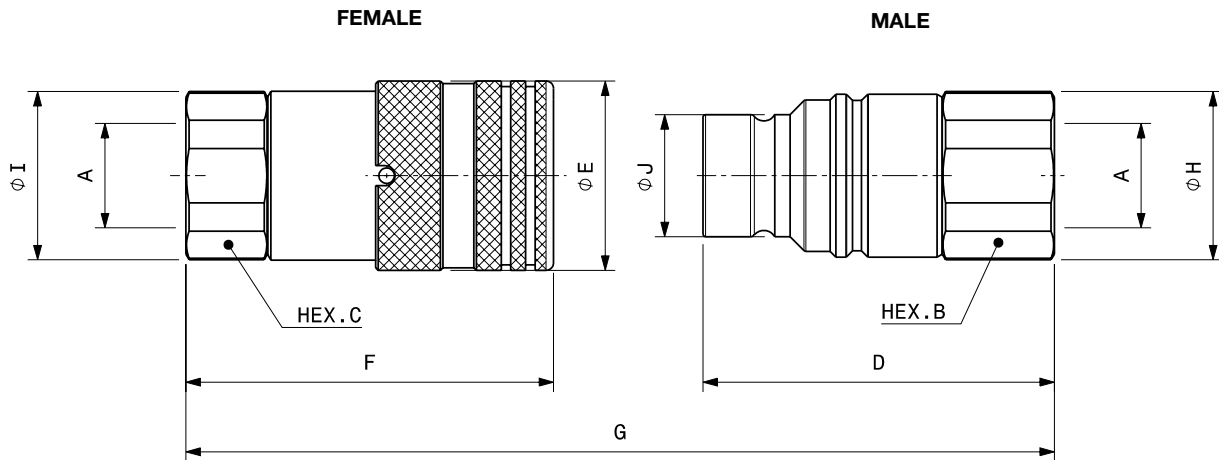

Port description: FEMALE THREAD BSPP (ISO 1179-1)

BODY SIZE	Descriptive Code	Item Code	ISO DN	PORT (A)	Overall Length	Length		Hex		Diameter		Diameter		Weight							
						mm	inch	mm	inch	mm	inch	mm	inch	Kg	Lbs						
1/8"	F FL4 1/8 BSP	Female 802400122	-	1/8"	G	68,4	2,69	F	40,0	1,57	C	19,0	0,75	I	20,5	0,81	E	20,0	0,79	0,07	0,16
	M FL4 1/8 BSP	Male 802400123						D	36,3	1,43	B	17,0	0,67	H	18,5	0,73	J	11,6	0,46	0,04	0,08
1/4"	F FL7 1/4 BSP	Female 802400100	6,3	1/4"	G	86,7	3,41	F	48,3	1,90	C	22,0	0,87	I	23,8	0,94	E	28,0	1,10	0,14	0,31
	M FL7 1/4 BSP	Male 802400101						D	49,4	1,94	B	22,0	0,87	H	23,8	0,94	J	16,1	0,63	0,10	0,22
3/8"	F FL9 3/8 BSP	Female 802400102	10	3/8"	G	108,6	4,28	F	64,2	2,53	C	27,0	1,06	I	29,0	1,14	E	32,0	1,26	0,25	0,54
	M FL9 3/8 BSP	Male 802400103						D	59,9	2,36	B	24,0	0,94	H	26,0	1,02	J	19,7	0,78	0,12	0,27
3/8"	F FL9 1/2 BSP	Female 802400104	10	1/2"	G	116,1	4,57	F	69,2	2,72	C	27,0	1,06	I	29,0	1,14	E	32,0	1,26	0,24	0,53
	M FL9 1/2 BSP	Male 802400105						D	62,4	2,46	B	27,0	1,06	H	29,0	1,14	J	19,7	0,78	0,12	0,26
1/2"	F FL13 1/2 BSP	Female 802400106	12,5	1/2"	G	127,0	5,00	F	73,8	2,91	C	32,0	1,26	I	33,8	1,33	E	38,0	1,50	0,38	0,83
	M FL13 1/2 BSP	Male 802400107						D	70,5	2,78	B	32,0	1,26	H	33,8	1,33	J	24,5	0,96	0,26	0,57
1/2"	F FL13 3/4 BSP	Female 802400108	12,5	3/4"	G	134,0	5,28	F	80,8	3,18	C	36,0	1,42	I	38,5	1,52	E	38,0	1,50	0,38	0,83
	M FL13 3/4 BSP	Male 802400109						D	70,5	2,78	B	36,0	1,42	H	38,5	1,52	J	24,5	0,96	0,26	0,56
5/8"	F FL15 3/4 BSP	Female 802400110	16	3/4"	G	133,8	5,27	F	80,9	3,19	C	36,0	1,42	I	38,5	1,52	E	42,0	1,65	0,49	1,08
	M FL15 3/4 BSP	Male 802400111						D	70,5	2,78	B	36,0	1,42	H	38,5	1,52	J	27,0	1,06	0,28	0,62
3/4"	F FL17 1 BSP	Female 802400112	19	1"	G	153,3	6,04	F	92,9	3,66	C	46,0	1,81	I	49,5	1,95	E	48,0	1,89	0,80	1,75
	M FL17 1 BSP	Male 802400113						D	82,2	3,24	B	46,0	1,81	H	49,5	1,95	J	30,0	1,18	0,43	0,95
1"	F FL21 1-1/4 BSP	Female 802400114	25	1 1/4"	G	173,0	6,81	F	106,2	4,18	C	55,0	2,17	I	59,8	2,35	E	55,0	2,17	1,23	2,70
	M FL21 1-1/4 BSP	Male 802400115						D	90,0	3,54	B	55,0	2,17	H	59,8	2,35	J	36,0	1,42	0,67	1,48
1-1/2"	F FL27 1-1/2 BSP	Female 802400116	-	1 1/2"	G	214,8	8,46	F	132,4	5,21	C	65,0	2,56	I	72,0	2,83	E	80,0	3,15	2,91	6,41
	M FL27 1-1/2 BSP	Male 802400117						D	111,0	4,37	B	70,0	2,76	H	76,0	2,99	J	57,0	2,24	1,89	4,17
2"	F FL45 2 BSP	Female 802400118	-	2"	G	241,5	9,51	F	156,6	6,17	C	80,0	3,15	I	88,5	3,48	E	100,0	3,94	5,23	11,53
	M FL45 2 BSP	Male 802400119						D	123,8	4,87	B	75,0	2,95	H	83,5	3,29	J	73,0	2,87	2,29	5,05

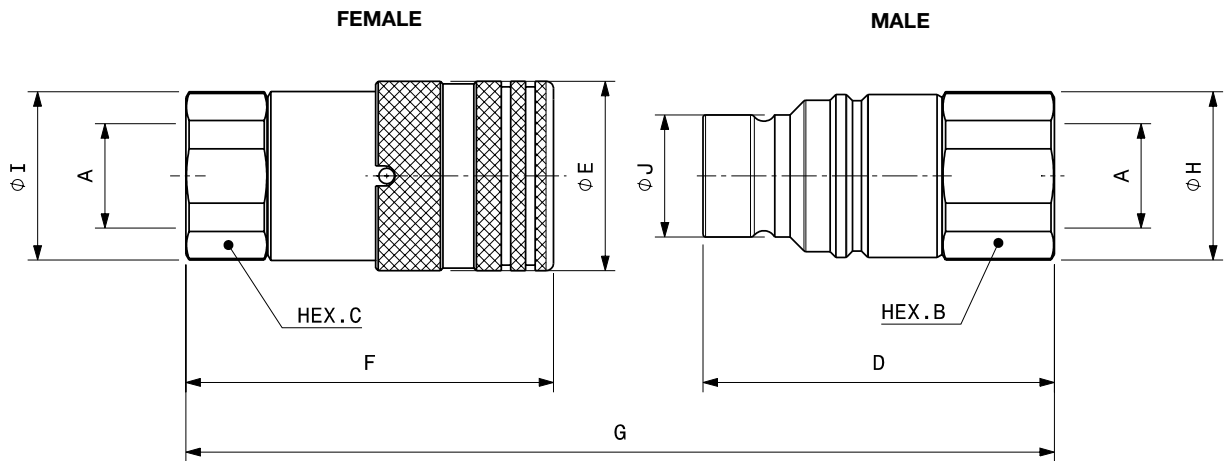

Port description: FEMALE THREAD NPT (ANSI B.1.20.1)

BODY SIZE	Descriptive Code	Item Code	ISO DN	PORT (A)	Overall Length	Length		Hex		Diameter		Diameter		Weight						
						mm	inch	mm	inch	mm	inch	mm	inch	mm	inch	Kg	Lbs			
1/8	F FL4 1/8 NPT	Female 802401118	-	1/8"	G 68,4	2,69	F	40,0	1,57	C	19,0	0,75	I	20,5	0,81	E	20,0	0,79	0,08	0,17
	M FL4 1/8 NPT	Male 802401119					D	36,3	1,43	B	17,0	0,67	H	18,5	0,73	J	11,6	0,46	0,04	0,09
1/4	F FL7 1/4 NPT	Female 802401100	6,3	1/4"	G 85,2	3,35	F	48,3	1,90	C	22,0	0,87	I	23,8	0,94	E	28,0	1,10	0,14	0,32
	M FL7 1/4 NPT	Male 802401101					D	47,9	1,89	B	22,0	0,87	H	23,8	0,94	J	16,1	0,63	0,09	0,21
3/8	F FL9 3/8 NPT	Female 802401102	10	3/8"	G 108,6	4,27	F	64,2	2,53	C	27,0	1,06	I	29,0	1,14	E	32,0	1,26	0,25	0,54
	M FL9 3/8 NPT	Male 802401103					D	59,9	2,36	B	24,0	0,94	H	26,0	1,02	J	19,7	0,78	0,14	0,30
3/8	F FL9 1/2 NPT	Female 802401104	10	1/2"	G 116,1	4,57	F	69,2	2,72	C	27,0	1,06	I	29,0	1,14	E	32,0	1,26	0,24	0,53
	M FL9 1/2 NPT	Male 802401105					D	62,4	2,46	B	27,0	1,06	H	29,0	1,14	J	19,7	0,78	0,14	0,30
1/2	F FL13 1/2 NPT	Female 802401106	12,5	1/2"	G 124,5	4,90	F	73,8	2,91	C	32,0	1,26	I	33,8	1,33	E	38,0	1,50	0,38	0,83
	M FL13 1/2 NPT	Male 802401107					D	68,0	2,68	B	32,0	1,26	H	33,8	1,33	J	24,5	0,96	0,26	0,57
1/2	F FL13 3/4 NPT	Female 802401108	12,5	3/4"	G 134	5,27	F	80,8	3,18	C	36,0	1,42	I	38,5	1,52	E	38,0	1,50	0,42	0,92
	M FL13 3/4 NPT	Male 802401109					D	70,5	2,78	B	36,0	1,42	H	38,5	1,52	J	24,5	0,96	0,27	0,59
5/8	F FL15 3/4 NPT	Female 802401110	16	3/4"	G 133,8	5,26	F	80,9	3,19	C	36,0	1,42	I	38,5	1,52	E	42,0	1,65	0,50	1,09
	M FL15 3/4 NPT	Male 802401111					D	70,5	2,78	B	36,0	1,42	H	38,5	1,52	J	27,0	1,06	0,28	0,62
3/4	F FL17 1 NPT	Female 802401112	19	1"	G 153,3	6,03	F	92,9	3,66	C	46,0	1,81	I	49,5	1,95	E	48,0	1,89	0,81	1,79
	M FL17 1 NPT	Male 802401113					D	82,2	3,24	B	46,0	1,81	H	49,5	1,95	J	30,0	1,18	0,43	0,95
1	F FL21 1-1/4 NPT	Female 802401114	25	1 1/4"	G 173	6,81	F	106,2	4,18	C	55,0	2,17	I	59,8	2,35	E	55,0	2,17	1,27	2,80
	M FL21 1-1/4 NPT	Male 802401115					D	90,0	3,54	B	55,0	2,17	H	59,8	2,35	J	36,0	1,42	0,78	1,72
1-1/2	F FL27 1-1/2 NPT	Female 802401116	-	1 1/2"	G 214,8	8,45	F	132,4	5,21	C	65,0	2,56	I	72,0	2,83	E	80,0	3,15	2,91	6,41
	M FL27 1-1/2 NPT	Male 802401117					D	111,0	4,37	B	70,0	2,76	H	76,0	2,99	J	57,0	2,24	1,90	4,18
2	F FL45 2 NPT	Female 802401120	-	2"	G 241,5	9,50	F	156,6	6,17	C	80,0	3,15	I	88,5	3,48	E	100,0	3,94	-	-
	M FL45 2 NPT	Male 802401121					D	123,8	4,87	B	75,0	2,95	H	83,5	3,29	J	73,0	2,87	-	-



SPARE KIT SEAL FOR MALE

Repair kit / OR+BK		
Body Size	Description	Part Number
3/8"	M FL9	815700247
1/2"	M FL13	815700249
5/8"	M FL15	815700251
3/4"	M FL17	815700253
1"	M FL21	815700255
1-1/2"	M FL 27	815700525
2"	M FL45	815700798

Back-up ring
(Teflon®)

o-ring

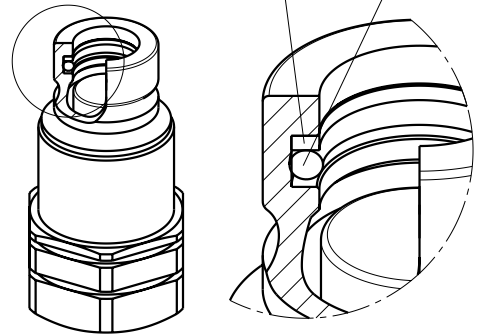

O-Ring in Viton®
BackUp in Teflon®

PROTECTIVE CAPS FOR FL SERIES

Protective caps are always recommended to protect the couplings from damage, dirt inclusion, and will increase the product life. This is particularly important in mobile applications where exposure to weather and aggregate materials are common.

The protective caps for FL couplings are manufactured in aluminum with lanyard (colors: natural aluminum).

Cap for FEMALE coupling
Aluminum

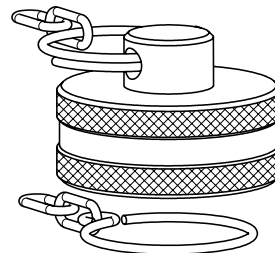

Cap for MALE coupling
Aluminum

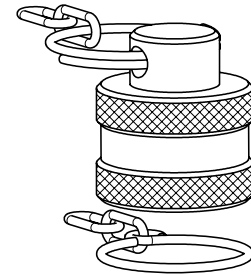

Body Size/Description		Protective Cap		Material/Color
		Part Number	Part Number	
		Cap for Female	Cap for Male	
1/4"	FL7	816005002	816005003	Aluminum/Natural
3/8"	FL9	816005004	816005005	Aluminum/Natural
1/2"	FL13	816005006	816005007	Aluminum/Natural
5/8"	FL15	816005008	816005009	Aluminum/Natural
3/4"	FL17	816005010	816005011	Aluminum/Natural
1"	FL21	816005012	816005013	Aluminum/Natural