

High Pressure Checkball Piston Pumps

PF1000 SERIES

1.5 to 5.9 gpm (5,7 to 22,3 L/min) at 1800 rpm
4000 to 6000 psi (280 to 420 bar)

Pressures to 10000 psi

Fixed delivery PF1000 Series pumps provide reliable high-pressure operation with models rated to:

6000 psi (420 bar) continuous and 10000 psi (700 bar) maximum.

Checkball pumps use piston check valves to direct flow from the pump inlet to the outlet. The check valves take the place of a valveplate, commonly used in other piston pump designs. The metal-to-metal rotating sealing surface in these other pumps is an inherent leak path, subject to wear and scoring.

High Volumetric Efficiency

The positive-seating action of the check valves provides better wear and higher volumetric efficiency, especially at higher pressures.

During operation the checkball rotates, providing a uniform, moving area of wear against the seat. The result is high efficiency even as the checkball wears.

Contamination Tolerant

The outlet check valves provide a relatively large flushing path for any system contamination. This makes the pumps ideal for systems where the fluid cannot be totally cleaned by filtration, or where it is just not economical.

PUMP SELECTION

The table shows specifications for standard pressure and high pressure "H" option models.

These pumps require a complete model code specifying shaft, seal and outlet port options. Refer to *Typical Model Code* on page 5.

Outlet Port Options

Standard pressure models have SAE ports. High pressure "H" option models require the use of outlet port option "A" medium pressure (Autoclave, Butech, or equivalent fitting), or outlet port option "B" (British Standard Pipe Parallel fitting).



Maximum Pressure

The pressures listed are the maximum pressures a pump can sustain for occasional, short periods of operation without appreciably reducing the life expectancy.

Multiple Outlet Models

Split-Flow® models provide multiple outputs for synchronized actuator movement or multiple function circuits. Contact the Dynex Sales department for options and availability.

Specifications

Pump Models	Output Flow at 1500 rpm ^①		Output Flow at 1800 rpm ^①		Rated Pressure		Max Pressure		Speed rpm ^②	
	U.S. gpm	L/min	U.S. gpm	L/min	psi	bar	psi	bar	Rated	Max
PF1002-10	1.3	4,9	1.5	5,7	6000	420	8000	560	1800	3600
PF1003-10	1.8	6,8	2.1	7,9	6000	420	8000	560	1800	3600
PF1004-10	2.2	8,3	2.6	9,8	6000	420	8000	560	1800	3600
PF1005-10	2.9	11,0	3.5	13,2	6000	420	8000	560	1800	2800
PF1006-10	3.4	12,9	4.1	15,5	6000	420	8000	560	1800	2800
PF1007-10	4.2	15,9	5.0	18,9	4000	280	6000	420	1800	2800
PF1008-10	4.9	18,5	5.9	22,3	4000	280	6000	420	1800	2800
PF1002H-10	1.3	4,9	1.5	5,7	6000	420	10 000	700	1800	3600
PF1003H-10	1.8	6,6	2.1	7,9	6000	420	10 000	700	1800	3600
PF1004H-10	2.2	8,3	2.6	9,8	6000	420	10 000	700	1800	3600
PF1005H-10	2.9	11,0	3.5	13,2	6000	420	10 000	700	1800	2800
PF1006H-10	3.4	12,9	4.1	15,5	6000	420	10 000	700	1800	2800

^① Output flow based on typical performance at rated pressure with pressurized inlet where required, as shown in the table on page 2.

^② Contact the Sales department for applications requiring operation above rated speed. High speed operation may require a pressurized inlet. Refer to "Inlet Conditions".

INSTALLATION AND OPERATION

Contact the Dynex Sales department for applications which require operating above rated pressures, speeds or normal temperatures, if fluid conditions fall outside of the range shown in the *Hydraulic Fluid Viscosity Guidelines* table, or if any other operating recommendations are needed.

Fluid

High-grade premium petroleum-based oil, with a combination of anti-wear, demulsibility, rust protection and oxidation resistance and foam resistance properties.

Some Dynex pumps are suitable for use with water-glycol, Skydrol and other phosphate ester fluids, and various military fluids.

Seals

Standard seals are Buna-N (Nitrile). Options include Fluorocarbon (Viton® or Fluorel®), Disogrin, or EPR (Ethylene-Propylene Rubber) outlet seals.

Inlet Conditions

Pumps may require pressurized inlet conditions at elevated speeds. Failure to meet inlet requirements will result in flow reduction. Refer to the *Minimum Inlet Pressure* table.

Inlet pressures higher than 10 psi (0,7 bar) require a high pressure shaft seal.

See *Typical Model Code* on page 5 for selecting seal options.

Minimum Inlet Pressure^①

Pump Models	Operating Speed							
	1800 rpm		2200 rpm		2800 rpm		3600 rpm	
	psi	bar	psi	bar	psi	bar	psi	bar
PF1002	0	0	0	0	0	0	5	0,4
PF1003 and PF1004	0	0	0	0	5	0,4	10 ^②	0,7 ^②
PF1005, PF1006, PF1007 and PF1008	0	0	5	0,4	10 ^②	0,7 ^②	–	–

① Values shown are based on fluid viscosity of 100 SUS (20 cSt).

② Inlet pressures higher than 10 psi (0,7 bar) require a high-pressure shaft seal. Refer to "Typical Model Code" on page 5 for seal options.

Hydraulic Fluid Viscosity Guidelines^①

Operating				Start-up ^②		Optimum	
Minimum		Maximum					
SUS	cSt	SUS	cSt	SUS	cSt	SUS	cSt
59	10	1580	342	1580	342	98 to 324	20 to 70

① If fluid conditions fall outside of the range shown, contact the Dynex Sales department.

② Under load or no-load.

Minimum Filtration Levels

Pump inlet, 150 μ nominal;
Pressure or return line, 25 μ nominal.

Finer filtration levels than these are desirable and will result in longer component life. Restricting flow to the pump inlet should be avoided.

Orientation

Generally, shaft horizontal with inlet vertically up. Contact the Dynex Sales department for applications requiring vertical shaft-up mounting or inlet orientation other than vertically up.

Bi-Directional Shaft Rotation

With these fixed displacement pumps, the direction of output flow is constant, regardless of drive shaft rotation.

INSTALLATION

All dimensions are shown in inches (millimeters in parentheses) and are nominal. See *Typical Model Code* on page 5 for selecting port options.

Mounting

SAE A 2-bolt pattern with 0.25 inch (6,4 mm) pilot engagement;
.875 inch (22,2 mm) diameter keyed shaft.

Optional Spline Shaft

.873/.872 inch diameter standard SAE 13 tooth, 16/32 DP 30° involute spline.

Weight (Mass)

30 lb (13,6 kg)

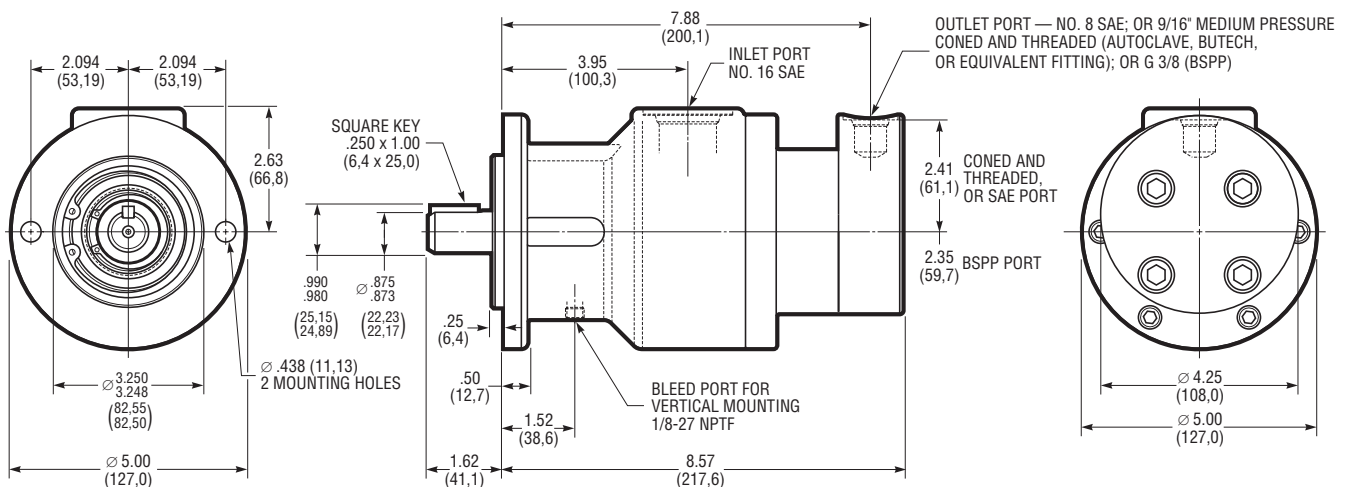

SPLIT-FLOW® MODELS

Split-Flow® provides multiple outlets from a single pump. Models with Split-Flow® covers efficiently supply two or more flows for multiple function circuits. Multiple outlet pumps can be used for synchronized actuator movement.

Piston outputs are grouped together in the cover with various piston flow splits available.

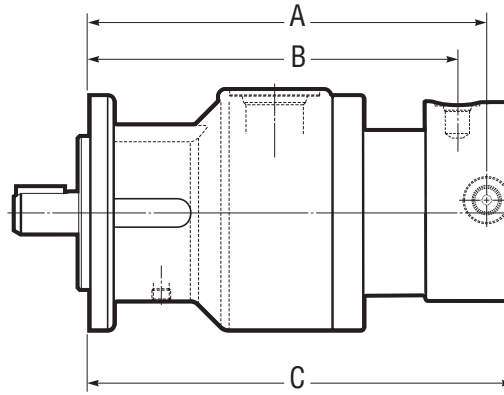

Variable Dimensions and Port Locations

DIM	2+2 SPLIT			3+1 SPLIT			4X SPLIT		
	SAE	C&T	BSPP	SAE	C&T	BSPP	SAE	C&T	BSPP
A	8.50 (216,0)	8.50 (216,0)	8.50 (216,0)	7.88 (200,1)	7.88 (200,1)	7.88 (200,1)	-	-	-
B	7.88 (200,1)	7.88 (200,1)	7.88 (200,1)	7.88 (200,1)	7.88 (200,1)	7.88 (200,1)	-	-	-
C	9.07 (230,3)	9.07 (230,3)	9.07 (230,3)	8.57 (217,6)	8.57 (217,6)	8.57 (217,6)	9.07 (230,3)	9.07 (230,3)	9.07 (230,3)

Abbreviations

C&T	Medium Pressure Coned and Threaded (Autoclave, Butech, or equivalent fitting)
SAE	Society of Automotive Engineers
BSPP	British Standard Pipe Parallel

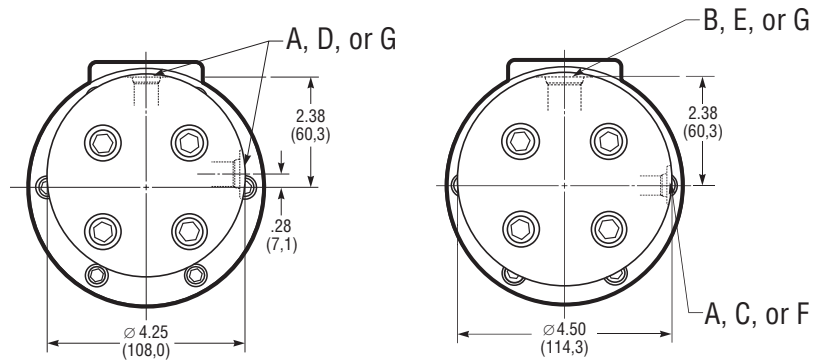

(2+2) Two-pistons output + two-pistons output (3+1) Three-pistons output + one-piston output

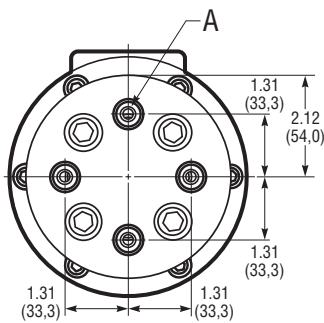

(4X) Four ports, each with one-piston output
C&T Ports

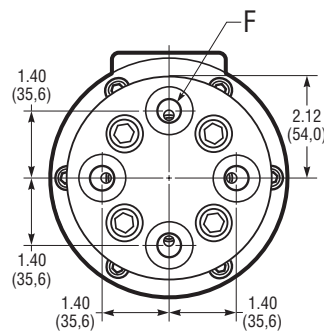

(4X) Four ports, each with one-piston output
BSPP Ports

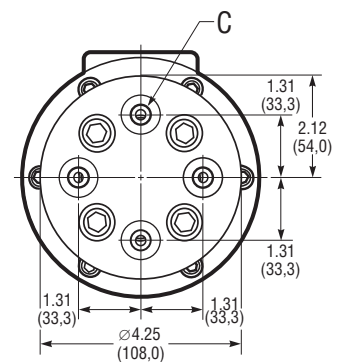

(4X) Four ports, each with one-piston output
SAE Ports

Port Options

Port	Port Type
A	3/8" Medium Pressure Coned and Threaded (Autoclave, Butech, or equivalent fitting)
B	9/16" Medium Pressure Coned and Threaded (Autoclave, Butech, or equivalent fitting)
C	SAE No. 4 Straight Thread O-Ring Boss .25 (6) Tube .4375-20 UNF-2B Thread
D	SAE No. 6 Straight Thread O-Ring Boss .375 (10) Tube .5625-18 UNF-2B Thread
E	SAE No. 8 Straight Thread O-Ring Boss .500 (12) Tube .750-16 UNF-2B Thread
F	G 1/4 1/4-19 BSPP Thread
G	G 3/8 3/8-19 BSPP Thread

Typical Performance Curves

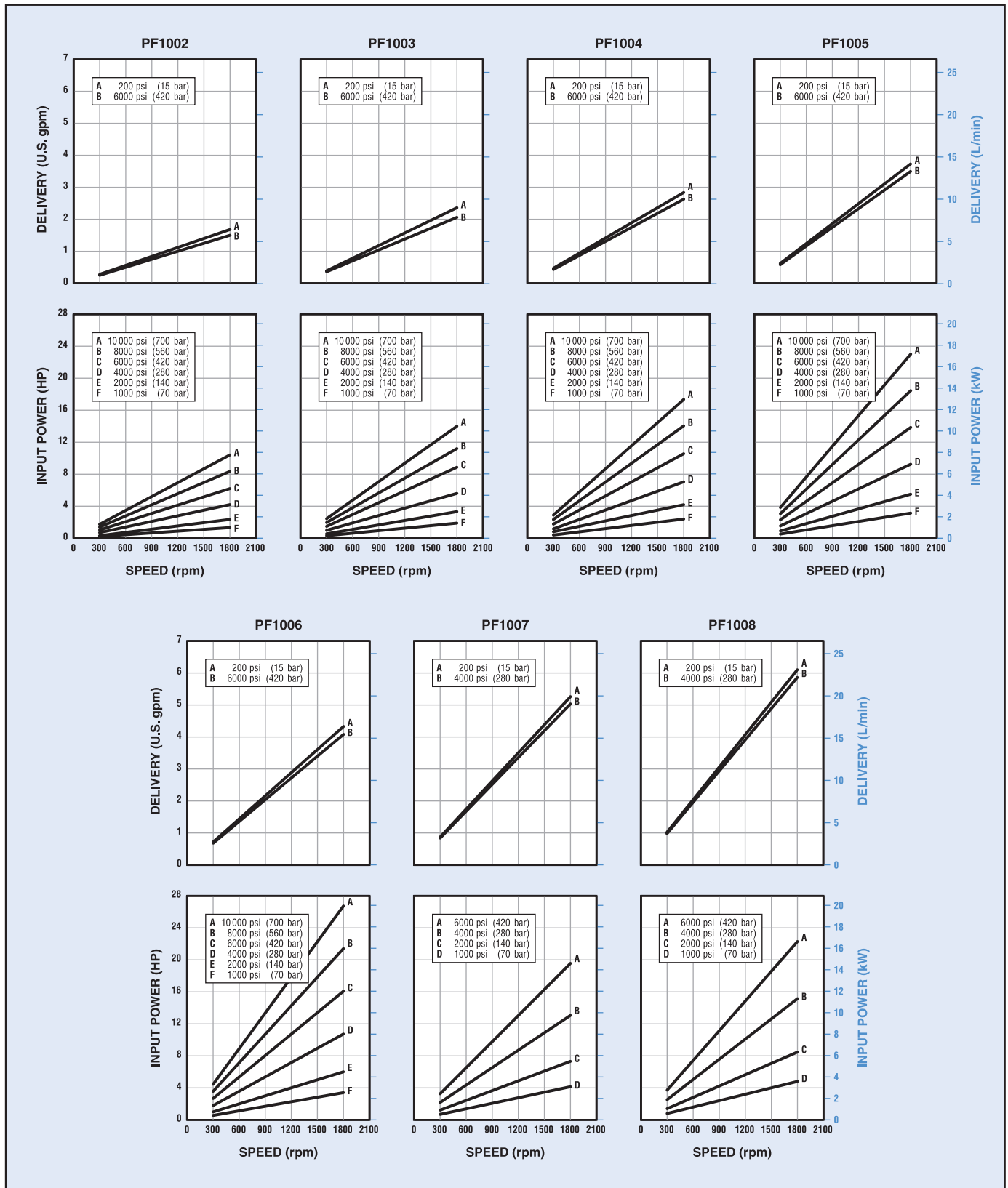

Typical performance curves are based on 100 SUS (20 cSt) mineral oil with pressurized inlet where required. Refer to the "Minimum Inlet Pressure" table on page 2.

TYPICAL MODEL CODE

PF10

02

H – S XV

A

–

22 – 1

0

Pump Type	
PF10	Fixed Displacement Checkball Pump

Output Flow (At 1800 rpm, at Rated Pressure) ^①	
02	1.5 gpm (5,7 L/min)
03	2.1 gpm (7,9 L/min)
04	2.6 gpm (9,8 L/min)
05	3.5 gpm (13,2 L/min)
06	4.1 gpm (15,5 L/min)
07	5.0 gpm (18,9 L/min) ^②
08	5.9 gpm (22,3 L/min) ^②

① Output flows based on typical performance at rated pressure. Refer to performance curves for flows at lower pressures.
② Not available with high pressure "H" option.

Operating Pressure	
No Code	Standard Pressure
H	High Pressure ^①

① Requires "A" or "B" port option.

Drive Shaft	
No Code	Keyed, 0.875 inch (22,20 mm) diameter
S	SAE Spline, 0.875 inch (22,20 mm)

Ports	
No Code	Inlet No. 16 SAE; Outlet No. 8 SAE ^①
A	Inlet No. 16 SAE; Outlet 9/16" Medium Pressure Coned and Threaded ^②
B	Inlet No. 16 SAE; Outlet G 3/8 (BSPP) ^③

① Not recommended for operation above 8000 psi (560 bar). Contact the fitting manufacturer for the pressure rating of the fitting.
② High pressure port uses medium pressure (Autoclave, Butech, or equivalent fitting).
③ Outlet port uses British Standard Pipe Parallel fitting. Not recommended for operation above 10000 psi (700 bar).

Split-Flow [®] Options (4 Piston Pump) ^①	
No Code	Full flow from single outlet
Split-Flow [®] Cover Models:	
22	Two-pistons output + two-pistons output
31	Three-pistons output + one-piston output
4X	Four ports, each with one-piston output
2	Two-pistons output + two inactive pistons

① For outlet port sizes, locations and pump cover dimensions, contact the Sales department.

Seals	
No Code	All Buna-N (Nitrile) ^①
D	Standard: Buna-N (Nitrile) with Disogrin [®] (Polyurethane) o-rings in the cover ^②
XE	All EPR (Ethylene-Propylene Rubber) with High Pressure Shaft Seal ^①
XV	All Fluorocarbon (Viton [®] or Fluorel [®]) with High Pressure Shaft Seal

① Not available with high pressure "H" option. Contact the Sales department for recommended operating conditions.
② Recommended in high pressure applications.

Design Number

Modification Number

Specifications shown were in effect when printed. Since errors or omissions are possible, contact your Sales representative or the Sales department for the most current specifications before ordering. Dynex reserves the right to discontinue products or change designs at any time without incurring any obligation.

www.dynexhydraulics.com

USA Headquarters
770 Capitol Drive
Pewaukee, WI 53072
Tel: +1 (262) 691-2222
FAX: +1 (262) 691-0312
sales@dynexhydraulics.com

Power Units & Systems
54 Nickerson Road
Ashland, MA 01721
Tel: +1 (508) 881-5110
ashland@dynexhydraulics.com

European Sales
Unit C5 Steel Close, Little End Road,
Eaton Socon, St Neots,
Cambs. PE19 8TT United Kingdom
Tel: +44 (0) 1480 213980 FAX: +44 (0) 1480 405662
sales@dynexhydraulics.co.uk



FLUID RECOMMENDATIONS (All Checkball Pumps)

Mineral Oil

A high-grade premium petroleum-based fluid should be used to assure long component and system life. The fluid should have a combination of anti-wear, demulsibility, rust protection, oxidation-resistant and foam-resistant properties.

Special Fluids

Various pump models are available for use with water-based fluids, diesel calibration fluids, phosphate ester fluids, machining coolant, brake fluid, various military fluids and other special fluids.

PF1300 & PF4300 Series pumps are compatible with a variety of water-based fluids. Refer to specific product documentation for specifications for these models, which are specifically rated for use with low-lubricity fluids.

Some pump models may require reduced operating pressures when using low-lubricity fluids.

Refer to separate bulletin: [Water-Based Fluid and Port Specifications](#) for use with water-based fluids.

Because of the wide range of fluid characteristics, contact the Sales department for a review of any application using non-petroleum based fluids.

Viscosity Specifications

Using fluid with the correct viscosity range is critical to achieving long component life.

Fluid conditions outside the "Optimum" range shown in the table may result in reduced pump output, requiring pressurized inlet conditions. For more information, contact the Sales department.

Hydraulic Fluid Viscosity^①

Pump Models	Operating				Start-up		Optimum	
	Minimum		Maximum		SUS	cSt	SUS	cSt
	SUS	cSt	SUS	cSt				
<i>Fixed Displacement Pumps:</i>								
PF500-20	52	8	1911	413	3706	800	98 to 324	20 to 70
PF1000-10	59	10	1911	413	3706	800	98 to 324	20 to 70
PF1300-11 ^②	–	–	–	–	–	–	–	–
PF2000-10	59	10	1911	413	1911	413	98 to 324	20 to 70
PF2000 ^③	34	2,3	1911	413	1911	413	98 to 324	20 to 70
PF3000-10	59	10	1911	413	3706	800	98 to 342	20 to 70
PF4000-30	34	2,3	1911	413	1911	413	98 to 324	20 to 70
PF4200-10	34	2,3	1911	413	1911	413	98 to 324	20 to 70
PF4300-22 ^②	–	–	–	–	–	–	–	–
PF6000	34	2,3	1911	413	1911	413	98 to 324	20 to 70
<i>Mechanical Variable Delivery Pumps:</i>								
PV4000-11	34	2,3	1911	413	1911	413	98 to 324	20 to 70
PV6000	34	2,3	1911	413	1911	413	98 to 324	20 to 70
<i>Hydraulic Variable Delivery Pumps:</i>								
PV6000	34	2,3	1911	413	1911	413	98 to 324	20 to 70

① Fluid conditions outside the "Optimum" range may result in reduced output, requiring pressurized inlet conditions. Contact the Sales department.

② Refer to separate bulletin "Water-Based Fluid and Port Specifications" for use with water-based fluids.

③ Models with special mounting.

MINIMUM FILTRATION LEVELS

Pump inlet: 150 μ nominal;

Pressure or return line: 25 μ nominal.

While finer filtration levels than these are desirable and will result in longer component life, restricting flow to the pump inlet should be avoided. Minimum recommended inlet conditions must be maintained.

If a system component fails resulting in fluid contamination, it is important to drain and clean the reservoir, all lines, filter screens and all components. Refill with new fluid.

INSTALLATION AND OPERATION

Refer to [Checkball Pumps Service, Installation and Operating Instructions](#) for general installation and operating recommendations.

That brochure includes information on mounting, shaft loading, sizing inlet pipe and hose, air bleed procedures and initial start-up. Guidelines for maintenance, repair and trouble-shooting are also included.

OUTLET PORT CONFIGURATIONS

Dynex pumps are available with outlet ports suitable for use at various pressure ranges. Refer to the appropriate *Specification Table* or *Typical Model Code* to specify the required port.

Contact the fitting manufacturer to ensure the selected fittings are rated for the maximum pump operating pressure.

SAE Straight Thread Ports

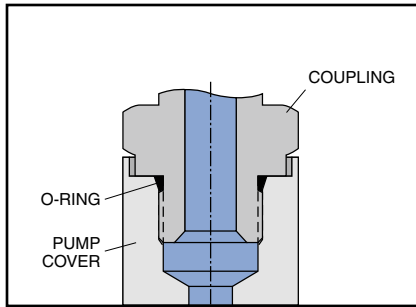

Typical SAE Straight Thread port connection

The Straight Thread connection (SAE J1926/1) is sometimes referred to as an SAE O-ring Boss, or ORB. The port consists of a machined spotface surface, a tapered seal cavity and a straight thread port.

The fitting forms a seal by compressing the o-ring in the seal cavity with the underside of the flanged wrench flat. Some adjustable fittings, such as elbows and tees, use a locknut with a captive backup washer for compression.

SAE Straight Thread ports are not recommended for operation above 8000 psi (560 bar). Also, the maximum pressure of pumps with No. 12 SAE outlet ports may be limited by the pressure rating of the available fitting. Contact the fitting manufacturer for ratings.

Coned and Threaded Ports

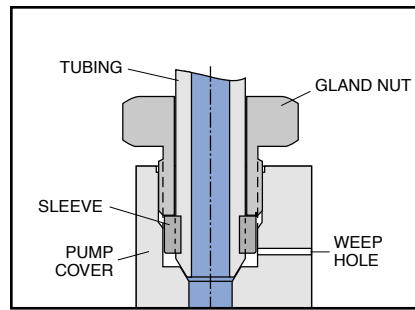

Typical Coned and Threaded port connection

High-pressure pumps are available with coned and threaded outlet ports, which use Autoclave Medium Pressure, Butech M/P, or equivalent fittings.

These fittings provide a metal-to-metal seal with an interference fit, not requiring an o-ring. The gland nut holds the sleeve and tubing against the cone surface.

A weep hole, visible on the outside of the pump cover, acts as an indicator of any abnormal leakage caused by system conditions (i.e., excessive pressure).

British Standard Pipe Parallel Ports

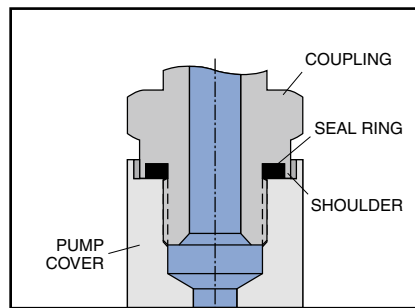

Typical British Standard Pipe (Parallel) port connection

High-pressure pumps are available with flat face ports with British Standard Pipe Parallel (BSPP) threads (BS 2779 or ISO 228), ideal for use on some European applications.

The fitting forms a seal by compressing a flat elastomer ring on a machined spotface surface. There are several sealing methods for these ports.

The recommended fitting has a recessed seal cavity formed by a shoulder on the underside of the flanged wrench flat (Voss "Peflex", Form B Shoulder Seal; or Parker Type E, "EOlastic" Seal; or equivalent).

BSPP ports are not recommended for operation above 10 000 psi (700 bar). Contact the fitting manufacturer to ensure the selected fittings are rated for the maximum pump operating pressure.

SAE 4-Bolt Flange Ports

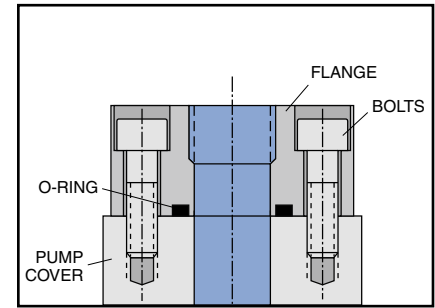

Typical SAE 4-Bolt Flange port connection

Flange connections are often used for higher flows requiring larger diameter tubing. The port consists of an unthreaded port with four bolt holes in a rectangular pattern on a machined face around the port (SAE J518).

A typical fitting consists of a flanged block with a welded tube and a captive flange with bolt holes. A seal is formed by an o-ring in the groove on the underside mounting surface of the flange head. As the flange bolts are alternately tightened, the o-ring is compressed between the flange head and the machined face on the pump.

To make mounting easier in tight spaces a two-piece split-flange is often used.